

web edition / www.fantoni.it

fantoni

TRE

TRE COLLECTION



Numero perfetto. Le tre dimensioni dell'ufficio di oggi: libertà, vivibilità, personalità. Una soluzione unica: la collezione Tre. Lunghi tavoli componibili, versatili elementi di servizio, colori e accessori che trasformano ogni posto di lavoro in un piccolo mondo personale. **A perfect number.** The three dimensions of the modern-day office: freedom, practicality and personality. A unique solution: the Tre collection. Long modular tables, versatile service units, colours and accessories that give each work station an individual touch. **Die perfekte Zahl.** Die drei Dimensionen im Büro von heute: Freiheit, Lebensqualität, Persönlichkeit. Eine Lösung: die Kollektion Tre. Lange, kombinierbare Tische, vielseitige Beistellelemente, Farben und Zubehör, die jeden Arbeitsplatz in eine kleine, individuelle Welt verwandeln. **Nombre parfait.** Les trois dimensions du bureau d'aujourd'hui : liberté, vivabilité, personnalité. Une solution unique : la collection Tre. Longs bureaux composables, éléments de service polyvalents, couleurs et accessoires qui transforment chaque poste de travail en un petit monde personnel. **Número perfecto.** Las tres dimensiones de la oficina de hoy: libertad, habitabilidad, personalidad. Una solución única: la colección Tre. Mesas largas componibles, elementos de servicio versátiles, colores y accesorios que transforman cada puesto de trabajo en un pequeño universo personal.



**Possibilità extra.**

Il tavolo "Extra Long" può raggiungere una lunghezza di 360 cm ed è proposto in una gamma completa di varianti: dalla semplice scrivania con fiancate, al tavolo a ponte da sovrapporre al tavolo di servizio per creare composizioni che estendono le tradizionali funzioni e valenze estetiche delle postazioni operative.

Extra possibilities.

The "Extra Long" table can be up to 360 cm in length and is available in a wide range of versions: from a simple desk with side panels to a bridging table that can be positioned over a service table to create configurations that extend the traditional functions and aesthetic values of work stations.

Möglichkeit extra.

Der Tisch "Extra Long" kann eine Länge von 360 cm erreichen und wird in einem kompletten Programm von Ausführungen angeboten: vom einfachen Schreibtisch mit Seitenteil bis zum Tisch, der als Brücke über dem Beistelltisch eingesetzt wird, um Kompositionen entstehen zu lassen, die Funktion und Ästhetik traditioneller Arbeitsplätze erweitern.

Possibilités extra.

Le bureau "Extra Long" peut atteindre une longueur de 360 cm et est proposé dans une gamme complète de variantes: du simple bureau avec piétements latéraux constitués d'un panneau plein, à la table en pont à superposer à la table de service, pour créer des compositions qui augmentent les fonctions traditionnelles et les qualités esthétiques des postes de travail.

Posibilidades extra.

La mesa "Extra Long" puede alcanzar una longitud de 360 cm y se propone en una gama completa de variantes: del simple escritorio con costados, a la mesa con configuración en forma de puente para superponer a la mesa de servicio y crear composiciones que amplían las funciones tradicionales y los valores estéticos de los puestos operativos.





106 **Molteplici sviluppi.**

L'architettura del posto di lavoro prende forma per accostamenti e sovrapposizioni di tavoli "Extra Long", schermi divisorii, cassettiere portanti ed elementi a giorno, in un libero gioco di piani, volumi, geometrie e colori.

Unlimited expansion.

The architecture of the work station takes shape by placing "Extra Long" tables, divider screens, supporting drawer boxes and open units next to and over each other, in a free play of surfaces, volumes, geometries and colours.

Vielfältige Entwicklungen.

Der Aufbau von Arbeitsplätzen nimmt Form an: durch Kombination und Überlagerung von Tischen "Extra Long", Trennschirmen, tragenden Schubladenkästen und offenen Schrankelementen, alles im beliebigen Spiel mit Platten, Volumen, Geometrien und Farben.

Développements multiples.

L'architecture du poste de travail prend forme par juxtapositions et superpositions de bureaux "Extra Long", panneaux écran, caissons porteurs et éléments ouverts, en un libre jeu de plans, volumes, géométries et couleurs.

Desarrollos múltiples.

La arquitectura del puesto de trabajo adquiere forma gracias a las combinaciones y a las superposiciones de las mesas "Extra Long", paneles separadores, cajoneras de soporte y elementos sin puertas, en un juego libre de planos, volúmenes, geometrías y colores.

107 **TRE COLLECTION**











**Colorata
funzionalità.**

Il mobile di servizio offre una superficie da appoggio per tecnologie e materiali di lavoro da condividere con i colleghi, ma allo stesso tempo rappresenta un elemento estetico, introducendo la valenza espressiva di colori di tendenza: amaranto, verde e giallo, in abbinamento al grigio nebbia e al rovere.

**Colourful
functionality.**

The service unit provides a surface on which to place office equipment and materials to be shared between co-workers, while at the same time enhancing overall appearance by introducing the expressive value of fashionable colours: amaranth, green and yellow, combined with misty grey and oak.

**Farbige
Zweckmäßigkeit.**

Mit dem Beistellmöbel wird eine Auflagefläche für Technologien und Arbeitsunterlagen geboten, die mit Kollegen geteilt wird, aber gleichzeitig ist es ein ästhetisches Element, das eine neue, expressive Dimension durch trendige Farben hinzufügt: Amaranthrot, Grün und Gelb, in Verbindung mit Nebelgrau und Eiche.

**Fonctionnalité
colorée.**

Le meuble de service offre une surface d'appui pour les équipements bureautiques et le matériel de travail à partager avec les collègues, mais il représente en même temps un élément esthétique introduisant la force expressive des couleurs mode: amarante, vert et jaune, associé au gris brouillard et au chêne.

**Funcionalidad
coloreada.**

El mueble de servicio ofrece una superficie de apoyo para las tecnologías y los materiales de trabajo que se comparten con los compañeros de trabajo, pero que al mismo tiempo representa un elemento estético, introduciendo la característica expresividad de los colores de tendencia: granata, verde y amarillo, combinado con el gris niebla y el roble.



Tre per tutti. I tavoli sagomati permettono di creare delle composizioni multiple, capaci di riunire in un'unica postazione di lavoro, tutte le diverse valenze dell'ufficio contemporaneo: ergonomia e creatività, colore e rigore, modularità e personalizzazione.

Three for all. Shaped tables make it possible to create multiple configurations, combining all the advantages of the contemporary office in a single work station: ergonomic design and creativity, colour and clean lines, modularity and personalisation.

Drei für alle. Mit den besonders geformten Tischen können Mehrfachplätze zusammengestellt werden, um alle Anforderungen, die an ein modernes Büro gestellt werden, mit einer Arbeitsstation erfüllen zu können: Ergonomie und Kreativität, Farbe und Rigorosität, Modulbauweise und individuelle Gestaltung. **« Tre » pour tous.** Les bureaux non linéaires permettent de créer des compositions multiples, capables de réunir dans une unique poste de travail, toutes les qualités du bureau contemporain : ergonomie et créativité, couleur et rigueur, modularité et personnalisation. **Tre para todos.** Las mesas curvadas permiten crear composiciones múltiples, capaces de reunir en una estación única de trabajo, todas las fuerzas que califican la oficina contemporánea: ergonomía y creatividad, color y rigor, modularidad y personalización.





**Libere associazioni.**

Piani sagomati a 90° e 120°, top di raccordo, piani rettangolari anche su misura, basi metalliche a T o cilindriche si affiancano agli altri elementi della collezione: dai tavoli di servizio, ai contenitori, agli schermi divisorii, permettendo la massima libertà di progettazione, organizzazione e utilizzo dello spazio.

Free associations.

Shaped surfaces at 90° and 120°, connecting tops, rectangular surfaces which can also be made to measure and metal 'T'-shaped or cylindrical bases combine with other components of the collection: from service tables to storage units and divider screens. They allow maximum freedom for designing, organising and using space.

Freie Assoziationen.

Platten auf 90° und auf 120°, Verbindungsplatten, rechteckige Platten auch nach Maß, metallische Untergestelle aus T-Profil oder zylindrisch, können mit anderen Elementen der Kollektion verbunden werden: Beistelltische, Schrankelemente und Trennschirme geben maximale Freiheit in Planung, Organisation und Nutzung von Räumen.

Associations libres.

Plans découpés à 90° et à 120°, plans de liaison, plans rectangulaires également sur mesure, piètements métalliques en T ou cylindriques, ils se juxtaposent aux autres éléments de la collection : des tables de service, aux armoires, aux panneaux écran, permettant la plus grande liberté de projet, d'organisation et d'utilisation de l'espace.

Libres asociaciones.

Tableros curvados de 90° y 120°, encimera de unión, tableros rectangulares también a medida, bases metálicas en forma de T o cilíndricas, se combinan con otros elementos de la colección: mesas de servicio, armarios y paneles separadores, permitiendo la máxima libertad de proyecto, organización y uso del espacio.





124 Atmosfere leggere.

L'originale decoro stilizzato può essere realizzato anche sugli ampi tavoli da riunione rettangolari, di lunghezza 240 cm, nonché sullo schienale delle sedute coordinate, realizzate con un'unica scocca in multistrato curvato: un segno di naturale calore e di luminosa leggerezza.

Light atmospheres.

The unusual, stylised decoration is also available on large, 240 cm long meeting tables and on the backrests of coordinating chairs, made using a one-piece shell in curved plywood: a hint of natural warmth and bright airiness.

Ein Hauch Schwerelosigkeit.

Ebenfalls realisierbar ist die originelle, stilisierte Dekoration auf den großzügigen, rechteckigen Konferenztischen, Länge 240 cm, sowie auf dem Rückteil der dazu passenden Sitzmöbel mit durchgehender Sitzschale aus gebogener Mehrschichtplatte: ein Zeichen für natürliche Wärme und helle Leichtigkeit.

Atmosphères légères.

Le décor original stylisé peut être réalisé également sur les grandes tables de réunion rectangulaires, de 240 cm de longueur, ainsi que sur le dossier des sièges assortis, réalisés avec une coque unique en multiplis courbé : un signe de chaleur et de légèreté lumineuse.

Atmósferas leves.

La decoración estilizada original puede ser realizada también en las amplias mesas de reunión rectangulares, de 240 cm de longitud, así como en el respaldo de los asientos coordinados, realizados con una estructura única en estratificado curvado: un signo de natural calidez y luminosa ligereza.

125 TRE COLLECTION



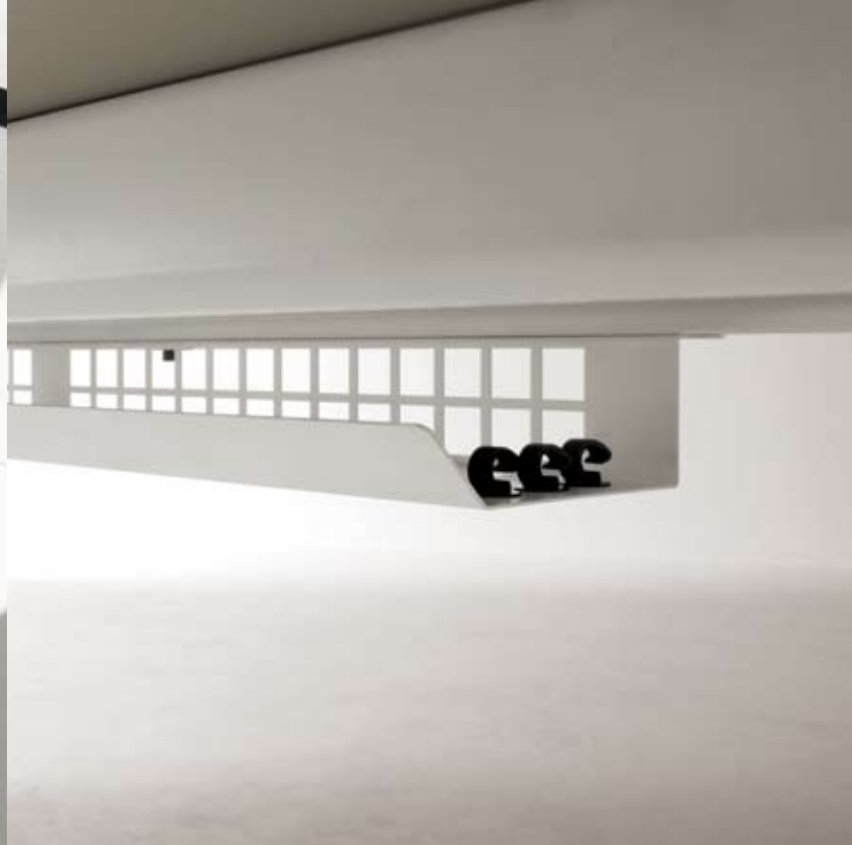

Tecnologie essenziali.

Parte integrante del lavoro d'ufficio, la tecnologia si inserisce con discrezione nel design della collezione Tre, sfruttando una serie di soluzioni attentamente studiate per unire funzionalità, accessibilità e immediatezza: canaline trasparenti, vaschette sottopiano, cestelli portacavi, supporti porta CPU.

Technology made simple.

Technology, an integral part of office work, blends discretely into the design of the Tre collection, using a number of solutions carefully devised to combine functionality, accessibility and immediateness: transparent ducting, storage trays under the top, cable racks and CPU holders.

Essentielle Technologien.

Technologie, ein wesentlicher Teil der Arbeit im Büro, fügt sich mit Diskretion in das Design der Kollektion Tre ein und nutzt dabei eine Reihe sorgfältig entwickelter Lösungen, die Funktionalität, Zugänglichkeit und Unmittelbarkeit garantieren: transparente Kabelkanäle, Schalen unter Tischplatten, Kabelkörbe, Computer-Halterung.

Technologies essentielles.

Partie intégrante du travail de bureau, la technologie s'insère avec discrétion dans le design de la collection Tre, en exploitant une série de solutions étudiées attentivement pour associer la fonctionnalité, l'accessibilité et la rapidité : goulottes transparentes, bacs sous le plan, paniers pour câbles, supports pour unité centrale.

Tecnologías esenciales.

Parte integrante del trabajo de oficina, la tecnología entra discretamente en el diseño de la colección Tre, aprovechando una serie de soluciones estudiadas atentamente para unir funcionalidad, accesibilidad e inmediatez: canales transparentes, bandejas debajo del tablero, cestas portacables, soportes para CPU.

**Organizzare le idee.**

Un'ampia proposta di classificatori e contenitori soddisfa tutte le esigenze pratiche ed estetiche dello spazio ufficio: a giorno, con ante in legno oppure in vetro. Sono inoltre possibili composizioni multiple di contenitori affiancati, sui quali vengono posizionati degli appositi top di finitura dai bordi arrotondati.

Organising ideas.

A wide range of filing units and cabinets meet all the practical and aesthetic needs in the office: open, with wood or glass doors. Several cabinets can also be placed side-by-side and covered with special, rounded-edge finishing tops to create multiple configurations.

Ideen organisieren.

Durch ein breites Angebot von Akten- und Schrankmöbeln können sowohl die praktischen als auch ästhetischen Anforderungen an den modernen Bürobereich erfüllt werden: offen, mit Holz- oder Glastüren. Außerdem können Schrankelemente zu mehrfachen Kompositionen aneinandergereiht und durch Oberplatten mit gerundeten Kanten abgeschlossen werden.

Organiser les idées.

Une proposition variée de classeurs et armoires satisfait toutes les exigences pratiques et esthétiques de l'espace bureau : sans portes, avec portes, avec portes en bois ou en verre. Possibilité de compositions multiples d'armoires juxtaposées sur lesquelles sont placés des plateaux de finition avec bords arrondis.

Organizar las ideas.

Una amplia propuesta de carpeteros y armarios ofrece una respuesta a todas las exigencias prácticas y estéticas del espacio de oficina: sin puertas, con puertas de madera o de vidrio. Además, se pueden formar composiciones múltiples de armarios adosados, sobre los cuales se colocan las encimeras de acabado con cantos redondeados.

Tavolo rettangolare_Rectangular table_
Rechteckiger Tisch_Table rectangulaire_Mesa
rectangular

P80 H72
64-1R20 L 200 64-1R32 L 320
64-1R24 L 240 64-1R36 L 360
64-1R28 L 280

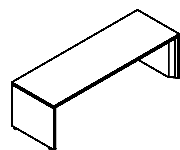

Tavolo rettangolare decorato_Decorated
rectangular table_Rechteckiger Tisch in
Dekorationsführung_Bureau rectangulaire
décoré_Mesa rectangular decorada

P80 H72
64-1R21 L 200 64-1R33 L 320
64-1R25 L 240 64-1R37 L 360
64-1R29 L 280

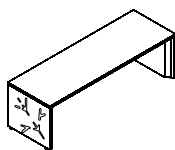

Tavolo penisola_Peninsula table_Halbinsel-
Tisch_Bureau en épi_Ala de extensión de
mesa

P80 H72
64-1R40 L 200
64-1R44 L 240
64-1R48 L 280

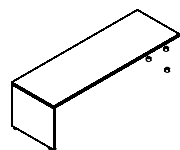

Tavolo penisola decorato_Decorated
peninsula table_Halbinsel-Tisch in
Dekorationsführung_Bureau en épi décoré_Ala
de extensión decorada

P80 H72
64-1R41 L 200
64-1R45 L 240
64-1R49 L 280

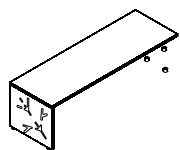

Tavolo di servizio_Side table_Beistelltisch_
Table de service_Mesa de servicio

P40 H62
64-1R60 L 200 64-1R72 L 320
64-1R64 L 240 64-1R76 L 360
64-1R68 L 280

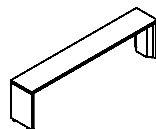

Tavolo di servizio decorato_Beistelltisch in
Dekorationsführung_Decorated side table_
Table de service décorée_Mesa de servicio
decorada

P40 H62
64-1R61 L 200 64-1R73 L 320
64-1R65 L 240 64-1R77 L 360
64-1R69 L 280

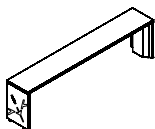

Carter per fianchi tavoli P80_Casing for sides
of P80 tables_Seitenabdeckung für Tische
P80_Enjoliveur pour piétements bureaux
P80_Panel de cubierta para los costados de
la mesa P80

L74 P5 H66
64-BR96 pz. 1

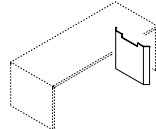

Carter per fianchi tavoli P40_Casing for sides
of P40 tables_Seitenabdeckung für Tische
P40_Enjoliveur pour piétements bureaux
P40_Panel de cubierta para los costados de
la mesa P40

L34 P5 H56
64-BR98 pz. 1

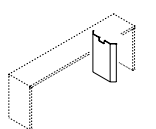

Cassettiera portante, 3 cassetti_Supporting
drawer box, 3 drawers_Tragender
Schubladenkasten, 3 Laden_Caisson
porteur, 3 tiroirs_Cajonera de soporte, 3
cajones

L42 P57 H58+S
64-6R89

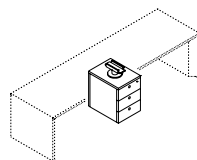

Cassettiera portante, 1cassetto/
1classif._Supporting drawer box, 1 drawer/
1 filing drawer_Tragender
Schubladenkasten, 1 Lade/1 Karteiausz_
Caisson porteur, 1 tiroir/1 classeur_Cajonera
de soporte, 1 cajón/1 carpetero

L42 P57 H58+S
64-6R90

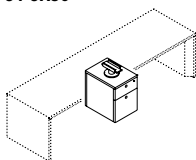

Base per tavoli Extra long H62/72_Base for
Extra Long tables H62/72_Untergestell für
Tische Extra Long H62/72_Piètement pour
bureaux Extra Long H62/72_Apoyo para
mesas Extra Long, H62/72

Ø 6 H72 64-BR87
Ø 6 H62 64-BR88

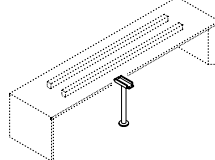

Mobile a giorno, monofronte_Open-fronted
unit with single front panel_Offenes
Element, eine Front_Armoire ouverte 1
face_Armario sin puertas, frente único

L80 P40 H41
64-7R18

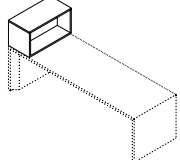

Mobile bifronte (divisorio plexiglas)_Unit
with double front panel (Plexiglas partition)_
Element mit zwei Fronten (Trennwand aus
Plexiglas)_Armoire ouverte 2 faces
séparation en plexiglas_Armario doble
frente (divisorio en plexiglas)

L80 P40 H41
64-7R28

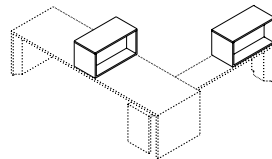

Mobile sospeso monofronte_Suspended
unit with single front panel_Hängeelement
eine Front_Meuble suspendu 1 face_
Armario suspendido frente único

L80 P40 H41
64-7R38

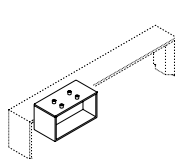

Pensile a muro, anta scorrevole_Wall unit,
sliding door_Hängeschrank, mit Schiebetür_
Meuble haut, porte coulissante_Mueble alto,
puerta corredera

L160 P32 H41
64-7R48

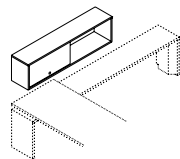

Libreria per tavoli penisola_Bookcase for
peninsula tables_Bücherschrank für
Halbinsel-Tische_Meuble bibliothèque pour
bureaux en épi_Librería para alas de
extensión de mesa

L240 P40 H62
64-7R58

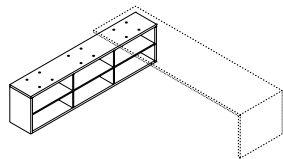

Esempi di composizioni_Combination
example_Anbau-Beispiele_Exemples de
compositions_Ejemplos de composición

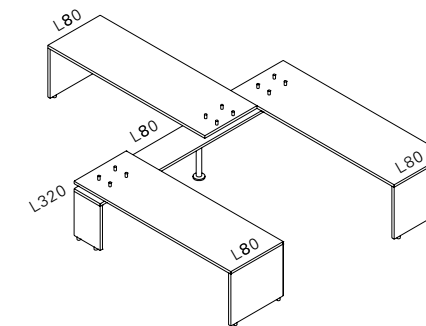
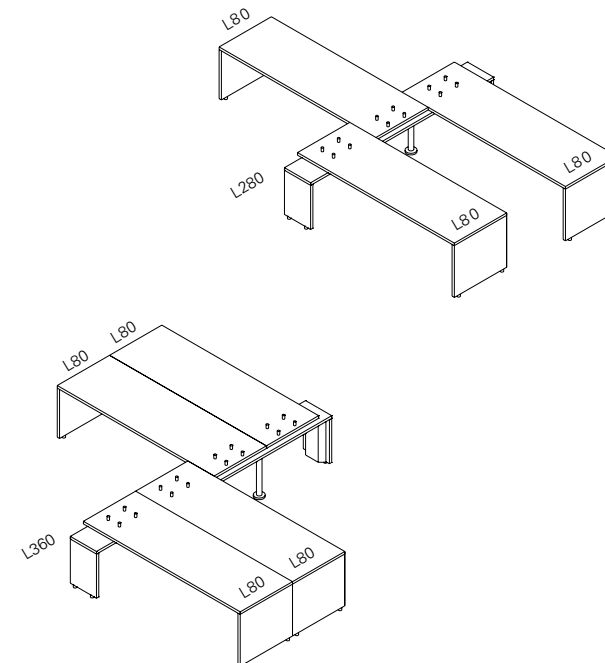
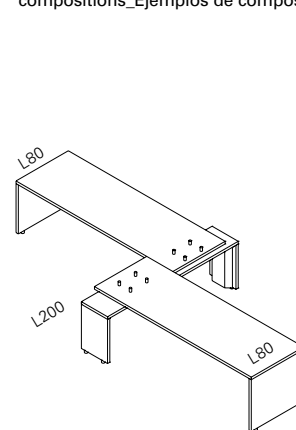

Consigli d'uso degli accessori, in
composizioni con tavoli molto lunghi_
Recommended uses of accessories in
compositions with extra long tables_
Empfehlung für den Einsatz von Zubehör
bei sehr langen Tischkombinationen_
Conseils d'utilisation des accessoires, dans
des compositions avec bureaux très longs_
Consejos para el uso de accesorios en
composiciones con mesas muy largas

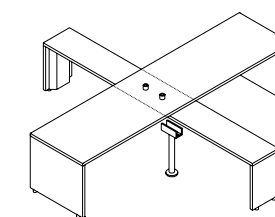
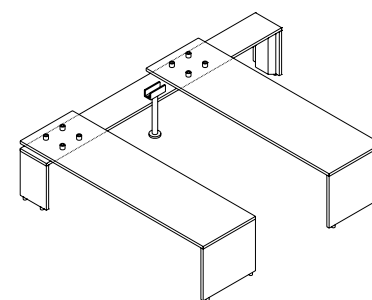
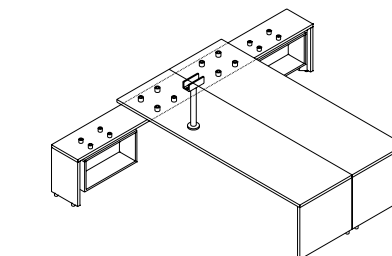
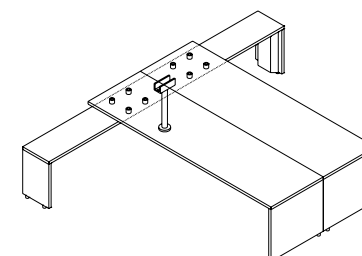

Tavolo rettangolare_Rectangular desk_
Rechteckiger Tisch_Bureau rectangulaire_
Mesa rectangular

P80 H72
64-1R08 L 80 64-1R16 L 160
64-1R12 L 120 64-1R18 L 180
64-1R14 L 140

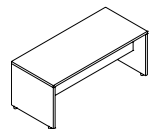

Tavolo rettangolare decorato_Decorated
rectangular table_Rechteckiger Tisch in
Dekorführung_Bureau rectangulaire
décoré_Mesa rectangular decorada

P80 H72
64-1R09 L 80 64-1R17 L 160
64-1R13 L 120 64-1R19 L 180
64-1R15 L 140

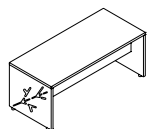

(*)Tavolo sagomato (90°)_Curved desk
(90°)_Bogenförmiger Tisch (90°)_Bureau
courbé (90°)_Mesa curvada (90°)

P140 H72 64-2R80
P160 H72 64-2R81

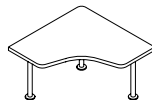

Tavolo sagomato (90°)_Curved desk (90°)_
Bogenförmiger Tisch (90°)_Bureau courbé
(90°)_Mesa curvada (90°)

P140 H72 64-2R78
P160 H72 64-2R79

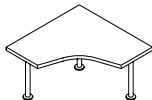

(*) Tavolo sagomato (90°)_Curved desk
(90°)_Bogenförmiger Tisch (90°)_Bureau
courbé (90°)_Mesa curvada (90°)

P140 H72 64-2R82
P160 H72 64-2R83

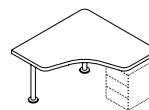

Tavolo sagomato (90°)_Curved desk (90°)_
Bogenförmiger Tisch (90°)_Bureau courbé
(90°)_Mesa curvada (90°)

P140 H72 64-2R84
P160 H72 64-2R85

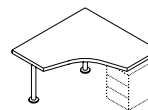

(*) Tavolo sagomato (120°)_Curved desk
(120°)_Bogenförmiger Tisch (120°)_Bureau
courbé (120°)_Mesa curvada (120°)

L209 P70- 111 H72
64-2R90

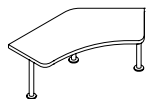

Tavolo sagomato (120°)_Curved desk (120°)_
Bogenförmiger Tisch (120°)_Bureau courbé
(120°)_Mesa curvada (120°)

L209 P70- 111 H72
64-2R96

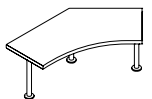

(*) Tavolo sagomato (120°)_Curved desk
(120°)_Bogenförmiger Tisch (120°)_Bureau
courbé (120°)_Mesa curvada (120°)

L209 P70-111 H72
64-2R91

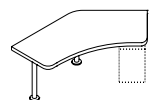

Tavolo sagomato (120°)_Curved desk (120°)_
Bogenförmiger Tisch (120°)_Bureau courbé
(120°)_Mesa curvada (120°)

L209 P70 -111 H72
64-2R97

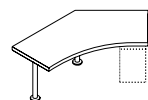

Tavolo autonomo_Free-standing table_
Freistehender Tisch_Bureau autonome_
Mesa autónoma

L120-60 P120-60 H72
64-2R92

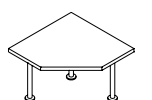

Tavolo di collegamento_Connecting table_
Verbindungstisch_Bureau de liaison_Mesa
de unión

L120-60 P120-60 H72
64-2R93

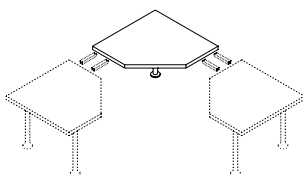

Piano di collegamento 90°_90° connecting
top_Verbindungsplatte 90°_Plan de liaison
90°_Módulo de unión 90°

P80
64-5R02

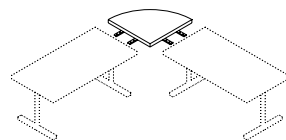

Piano terminale_End unit_Abschlussplatte_
Plan d'extension_Módulo terminal de
extensión

L80 P40
64-5R03

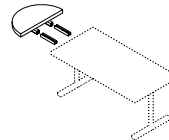

Tavolo rettangolare_Rectangular desk_
Rechteckiger Tisch_Bureau rectangulaire_
Mesa rectangular

P80 H72
64-2R08 L 80 64-2R16 L 160
64-2R12 L 120 64-2R18 L 180
64-2R14 L 140

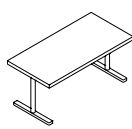

Tavolo intermedio_Bureau intermédiaire_
Intermediate desk_Bureau intermédiaire_
Mesa intermedia

P80 H72
64-2R58 L 80 64-2R66 L 160
64-2R62 L 120 64-2R68 L 180
64-2R64 L 140

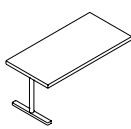

Tavolo dattilo_Typing desk_
Schreibmaschinentisch_Table dactylo_Mesa
dactilografía

P60 H72
64-2R30 L 80 64-2R38 L 160
64-2R31 L 100 64-2R40 L 180
64-2R32 L 120

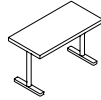

Tavolo intermedio_Intermediate desk_
Zwischentisch_Bureau intermédiaire_Mesa
intermedia

P60 H72
64-2R40 L 80 64-2R48 L 160
64-2R41 L 100 64-2R42 L 120

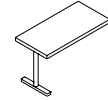

Cassettiera a 3 cassetti_Drawer box with 3
drawers_Schubladenkasten mit 3 Laden_
Caisson avec 3 tiroirs_Cajonera de 3 cajones

L42 P57 H58
64-6R07



Cassettiera, 1cassetto/1classif._Drawer box,
1 drawer/1 filing drawer_Schubladenkasten,
1 Lade/1 Karteiausz._Caisson, 1 tiroir/1
classeur_Cajonera, 1 cajón,1 carpetero

L42 P57 H58
64-6R08



Cassettiera portante, 3 cassetti_Supporting
drawer box, 3 drawers_Tragender
Schubladenkasten, 3 Laden_Caisson
porteur, 3 tiroirs_Cajonera de soporte, 3
cajones

L42 P57 H58+S
64-6R87

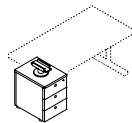

Cassettiera portante, 1 cassetto/1 classif. _
Supporting drawer box, 1 drawer/1 filing
drawer_Tragender Schubladenkasten,
1 Lade/1 Karteiauszug_Caisson porteur,
1 tiroir/1 classeur_Cajonera de soporte,
1 cajón/1 carpetero

L42 P57 H58+S
64-6R88

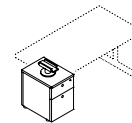

Set di 4 piedini fissi_Set of 4 fixed feet_
Garnitur 4 fixe Füße_Jeu de 4 pieds fixes_
Juego de 4 pies fijos

Ø 5 H1,7
53-9M93

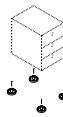

Tavolo riunione_Conference table_
Konferenztisch_Table de réunion_Mesa de
reunión

P120 H72 L240
64-3R44

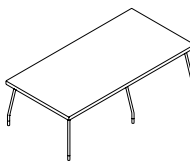

Tavolo riunione decorato_Decorated
conference table_Konferenztisch in
Dekorführung_Mesa de reunión
decorada_Mesa de reuniones

P120 H72 L240
64-3R45

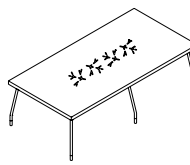

Tavolo rettangolare_Rectangular table_
Rechteckiger Tisch_Table rectangulaire_Mesa
rectangular

P80 H72
64-3R08 L 80 64-3R16 L 160
64-3R12 L 120 64-3R14 L 140

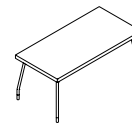

Tavolo rettangolare_Rectangular table_
Rechteckiger Tisch_Table rectangulaire_Mesa
rectangular

P100 H72
64-3R24 L 140 64-3R26 L 160

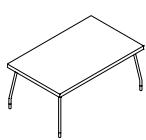

Tavolo con ruote_Table with casters_Tisch
mit Rollen_Table avec roulettes_Mesa con
ruedas

P80 H72
64-3R09 L 80 64-3R17 L 160
64-3R13 L 120 64-3R15 L 140

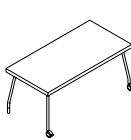

Tavolo con ruote_Table with casters_Tisch
mit Rollen_Table avec roulettes_Mesa con
ruedas

P100 H72
64-3R25 L 140 64-3R27 L 160

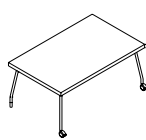

Piano rettangolare_Rectangular top_
Rechteckige Platte_Plateau rectangulaire_
Tablero rectangular

P80
64-PR20 L 80 64-PR22 L 120 64-PR24 L 140 64-PR26 L 160 64-PR28 L 180
P60
64-PR44 L 80 64-PR45 L 100 64-PR46 L 120

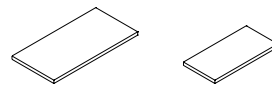

(*) Non disponibile per il mercato francese
Not available for the French market
Für Frankreich nicht erhältlich
Pas disponible pour le marché français
No disponible para el mercado francés

Tavolo tondo_Round table_Runder Tisch_
Table ronde_Mesa redonda

Ø90 H72
64-3R31



Tavolo tondo con ruote_Round table with
casters_Runder Tisch mit Rollen_Table ronde
avec roulettes_Mesa redonda con ruedas

Ø90 H72
64-3R41



Tavolo tondo_Round table_Runder Tisch_
Table ronde_Mesa redonda

Ø120 H72
64-3R32



Tavolo ovale_Oval table_Ovaler Tisch_Table
ovalada

L140 P80 H72
64-3R33



Tavolo rettangolare, regolabile_Rectangular
table, adjustable_Rechteckiger Tisch,
verstellbar_Bureau rectangulaire, réglable_
Mesa rectangular, regulable

P80 H72-120
64-TR14 L 140
64-TR16 L 160
220V ~50Hz 400W

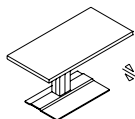

Tavolo ovale, regolabile
Oval table, adjustable_Ovaler Tisch,
verstellbar_Bureau ovale, réglable_Mesa
ovalada, regulable

P80 H72-120
64-TR26 L 160
220V ~50Hz 400W

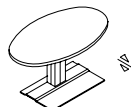

Tavolo sagomato, regolabile_Curved table,
adjustable_Bogenförmiger Tisch,
verstellbar_Bureau courbe, réglable_Mesa
curvada, regulable

L160 P80 H72-120
64-TR36
220V ~50Hz 400W

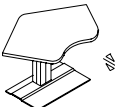

Piano per CPU
Computer stand_Computer-Auflageplatte_
Plateau pour ordinateur_Soporte para
ordenador

L45 P22 H57,5
64-9R92

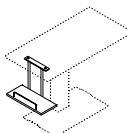

Schermo per CPU_Computer screening
panel_Abschirmung für Computer_Panneau
pour ordinateur_Panel para ordenador

L19 P5 H40
64-9R59

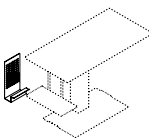

Pannello frontale metallico_Metal front
panel_Metallisches Frontpaneel_Panneau
frontal métallique_Panel frontal metálico

L100 P8 H32,5
64-9R60

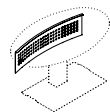

Piano di lavoro sagomato (90°)_Curved
worktop (90°)_Arbeitsplatte, bogenförmig (90°)_
Plan de travail courbe (90°)_Tablero curvado
(90°)

L140 P140 64-PR32
L160 P160 64-PR33

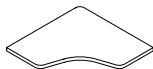

Piano di lavoro sagomato (90°)_Curved
worktop (90°)_Arbeitsplatte, bogenförmig
(90°)_Plan de travail courbe (90°)_Tablero
curvado (90°)

L140 P140 64-PR30
L160 P160 64-PR31

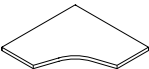

*Non disponibile per il mercato francese
Not available for the french market
Für Frankreich nicht erhältlich
Pas disponible pour le marché français
No disponible para el mercado francés*

Piano di lavoro sagomato (120°)_Curved
worktop (120°)_Arbeitsplatte, bogenförmig
(120°)_Plan de travail courbe (120°)
Tablero curvado (120°)

L209 P70-111
64-PR34

*Non disponibile per il mercato francese
Not available for the french market
Für Frankreich nicht erhältlich
Pas disponible pour le marché français
No disponible para el mercado francés*



Piano di lavoro sagomato (120°)_Curved
worktop (120°)_Arbeitsplatte, bogenförmig
(120°)_Plan de travail courbe (120°)
Tablero curvado (120°)

L209 P70-111
64-PR36



Piano di lavoro_Worktop_Arbeitsplatte_Plan
de travail_Tablero

L120-60 P120-60
64-PR35

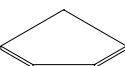

Piano di lavoro a misura_Custom worktop_
Arbeitsplatte nach Maß_Plan de travail sur
mesure_Tablero a medida

H 6,5 L. max.300cm
64-PR10 P 100
64-PR08 P 80
64-PR06 P 60

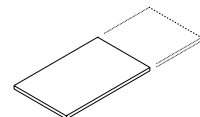

Base cilindrica_Cylindrical base_
Zylinderförmiges Fußgestell_Piètement
cylindrique_Apoyo cilíndrico

Ø6 H72
64-BR84

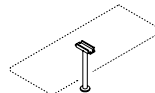

Base cilindrica, regolabile_Cylindrical base,
adjustable_Zylinderförmiges Fußgestell,
verstellbar_Piètement cylindrique, réglable_
Apoyo cilíndrico, regulable

Ø6 H67-77
64-BR94

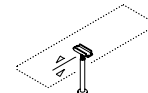

Base a T_T-shaped base_Fußgestell T-förmig_
Piètement T_Apoyo en T

L12 P68 H72
64-BR80
64-BR81 pezzi 1
pezzi 2

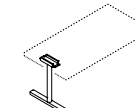

Base a T ridotta_Reduced T-shaped base_
Fußgestell T-förmig, reduziert_Piètement T
réduit_Apoyo en T reducido

L12 P50 H72
64-BR82
64-BR83 pezzi 1
pezzi 2

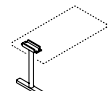

Base a T, regolabile_T-shaped base,
adjustable_Fußgestell T-förmig, verstellbar_
Piètement T, réglable_Apoyo en T regulable

L12 P68 H67-77
64-BR90
64-BR91 pezzi 1
pezzi 2

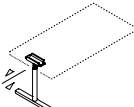

Base a T ridotta, regolabile_Reduced
T-shaped base, adjustable_Fußgestell
T-förmig reduziert, verstellbar_Piètement T
réduit, réglable_Apoyo en T reducido,
regulable

L12 P50 H67-77
64-BR92
64-BR93 pezzi 1
pezzi 2

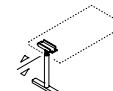

Pannello schermo vetro sabbato_Matt-finish
screen panel_Abschirmpaneel aus Mattglas_
Panneau écran satiné_Panel separador
vidrio arenado

H40 P0,5
64-4R22 L 119
64-4R24 L 139
64-4R26 L 159
64-4R28 L 179
64-4R30 L 199

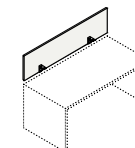

Pannello schermo nobilitato_Melamine
screen panel_Melamin-Abschirmpaneel_
Panneau écran mélaminé_Panel separador
melamínico

H50 P1,8
64-4R52 L 119
64-4R54 L 139
64-4R56 L 159
64-4R58 L 179
64-4R60 L 199

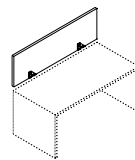

Pannello schermo nobilitato_Melamine
screen panel_Melamin-Abschirmpaneel_
Panneau écran mélaminé_Panel separador
melamínico

H50 P1,8
64-4R62 L 119
64-4R64 L 139
64-4R66 L 159
64-4R68 L 179
64-4R70 L 199

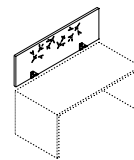

Pannello con binario alluminio_Panel with
aluminium rail_Paneel mit
Aluminiumschiene_Panneau avec rail en
aluminium_Panel con guía en aluminio

H50 P2,8
64-4R82 L 119
64-4R84 L 139
64-4R86 L 159
64-4R88 L 179
64-4R90 L 199

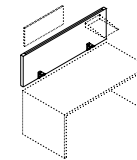

Pannello schermo bifronte_Double sided
screen pane_Doppelseitiges
Abschirmpaneel_Panneau écran biface
Panel separador doble frente

H50 P1,8
64-4R53 L 119
64-4R55 L 139
64-4R57 L 159
64-4R59 L 179
64-4R61 L 199

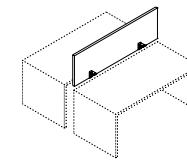

Pannello schermo bifronte_Double sided
screen pane_Doppelseitiges
Abschirmpaneel_Panneau écran biface
Panel separador doble frente

H50 P1,8
64-4R63 L 119
64-4R65 L 139
64-4R67 L 159
64-4R69 L 179
64-4R71 L 199

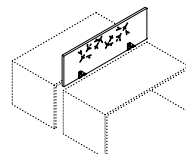

Pannello schermo bifronte_Double sided
screen pane_Doppelseitiges
Abschirmpaneel_Panneau écran biface
Panel separador doble frente

H50 P2,8
64-4R83 L 119
64-4R85 L 139
64-4R87 L 159
64-4R89 L 179
64-4R91 L 199

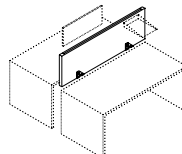

Contenitore a giorno_Open-fronted cabinet_
Offener Schrank_Armoire ouverte_Armario
sin puertas

L45 P43
64-7R00 H 81,7
64-7R10 H 121,7
64-7R20 H 161,7

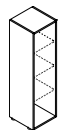

Contenitore anta legno (dx)_Cabinet with
wooden door (rh)_Schrank mit Holztüre (re)_
Armoire porte bois (d)_Armario puerta de
madera (dx)

L45 P45
Dx
64-7R04 H 81,7
64-7R14 H 121,7
64-7R24 H 161,7

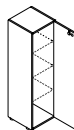

Sx
64-7R05 H 81,7
64-7R15 H 121,7
64-7R25 H 161,7

Contenitore anta vetro_Cabinet with glass
door_Schrank mit Glastüre_Armoire porte
vitrée_Armario puerta acristalada

L45 P44
64-7R09 H 81,7
64-7R19 H 121,7
64-7R29 H 161,7

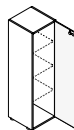

Ripiano per contenitori L45_Cabinet shelf,
L45_Fachboden für Schrank L45_Tablette
pour armoires L45_Estante para armarios
L45

L41,3 P40 H2,2
64-7R31 pezzi 1
64-7R32 pezzi 2
64-7R33 pezzi 3



Contenitore a giorno_Open-fronted cabinet_
Armoire ouverte_Armario sin puertas

L90 P43
64-7R01 H 81,7
64-7R11 H 121,7
64-7R21 H 161,7

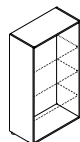

Contenitore ante legno_Cabinet with
wooden doors_Armoire portes bois_
Armario puertas de madera

L90 P45
64-7R02 H 81,7
64-7R12 H 121,7
64-7R22 H 161,7

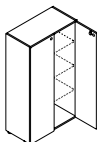

Contenitore ante vetro_Cabinet with glass
doors_Armoire portes vitrées_Armario
puertas acristaladas

L90 P44
64-7R03 H 81,7
64-7R13 H 121,7
64-7R23 H 161,7

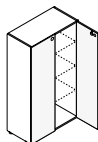

Ripiano per contenitori L90_Cabinet shelf,
L90_Fachboden für Schrank L90_Tablette
pour armoires L90_Estante para armarios
L90

L86,3 P40 H2,2
64-7R51 pezzi 1
64-7R52 pezzi 2
64-7R53 pezzi 3



Ripiano metallico per contenitori L90_Metal
shelf for cabinets, L90_Metallfachboden für
Schränke L90_Tablette métallique pour
armoires L90_Estante metálico para
armarios L90

L86,3 P40 H2,5
54-9E51 pezzi 1



Classificatore con 2 cassetti, prof. 33_Filing
drawer box with 2 drawers, depth 33_
Aktensmöbel mit 2 Laden, Tiefe 33_Classeur
avec 2 tiroirs, prof. 33_Carpetero con 2
cajones, prof. 33

L90 P45 H81,7
64-7R08



Anta per contenitori, con serratura_Door for
cabinets, with lock_Tür für Schränke, mit
Sperrung_Porte pour armoires, avec
serrure_Puerta para armarios, con cerradura

L45 P2
Dx
64-7R82 H 81,7
64-7R84 H 121,7
64-7R86 H 161,7
Sx
64-7R92 H 81,7
64-7R94 H 121,7
64-7R96 H 161,7



Coppia ante, con serratura_Pair of doors,
with lock_Türen (Paar), mit Sperrung_Paire
de portes, avec serrure_Par de puertas, con
cerradura

L90 P2
64-7R62 H 81,7
64-7R64 H 121,7
64-7R66 H 161,7



Coppia ante per sovrapposizione_Pair of
doors for stacking_Türen (Paar) für Montage
übereinander_Paire de portes pour
superposition_Par de puertas para
sobreposición

L90 P2
64-8R62 H 81,7
64-8R64 H 121,7
64-8R66 H 161,7

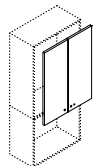

Top per contenitori_Top for cabinets
Schrankoberplatte_Dessus pour armoires_
Encimera para armarios

P45 H1,8
64-7R40 L 45
64-7R41 L 90
64-7R42 L 135
64-7R45 L 180
64-7R46 L 225
64-7R47 L 270

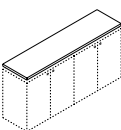

Cestone metallico con fondo_Large metal
basket with bottom_Metallkorb mit Boden_
Casier métallique avec fond_Gaveta
metálica con fondo

L90-86 P33 H20
53-CM05

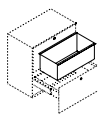

Pannello plexiglas_Plexiglas screen panel_
Frontpaneel aus Plexiglas_Panneau écran
plexiglas_Panel separador en plexiglas

H 30
58-0L05 L 50
58-0L07 L 70
58-0L09 L 90
58-0L11 L 110
58-0L13 L 130
58-0L15 L 150
58-0L17 L 170

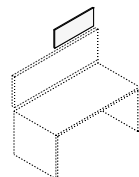

Vaschetta cancelleria alluminio_Aluminium
stationery tray_Schale für Bürotensilien,
Aluminium_Bac plumier en aluminium_
Bandeja para útiles en aluminio

L22 P31 H8
L32 P22 H8
L44 P31 H8
L66 P66 H8
58-0L20
58-0L21
58-0L22
58-0L23

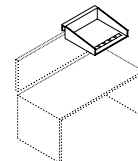

Vaschetta cancelleria plexiglas_Plexiglas
stationery tray_Schale für Bürotensilien,
Plexiglas_Bac plumier en plexiglas_Bandeja
para útiles en plexiglas

L22 P31 H8
L32 P22 H8
58-0L25
58-0L26

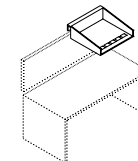

Accessorio reggilibri_Book stand accessory_
Bücherständer_Accessoire serre-livres_
Accessorio de soporte libros

L44
58-0L40

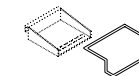

Cestello portacavi_Cable rack_Kabelkorb_
Corbeille porte-câbles_Bandeja portacables

L40 P16,5 H5,5
L96 P16,5 H5,5
64-9R81
64-9R82

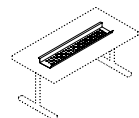

Supporto porta CPU_Computer stand_
Computer-Auflageplatte_Plateau pour
ordinateur_Soporte para ordenador

L60 P21 H52-47
64-9R20

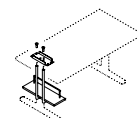

Canalina salita cavi_Cable riser ducting_
Vertikale Kabelführung_Conduit passe
câbles_Canal pasacables

Ø 6 H58
53-9M88

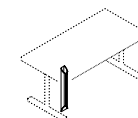

Canalina salita cavi_Cable riser ducting
Vertikale Kabelführung_Conduit passe
câbles_Canal pasacables

Ø 6 H75
55-9K75

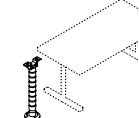

Ruota per tavoli con freno_Caster for tables
with brake_Gebremste Rolle für Tische_
Roulette pour tables avec frein_Rueda para
mesas con freno

H6 Ø5
64-9R35

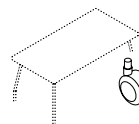

Set 4 ruote per cassettiere_Set of casters for
drawer boxes, 4pcs._Garnitur 4 Rollen für
Schubladenkästen_Jeu de 4 roulettes pour
caissons_Juego de 4 ruedas para cajoneras

H6 Ø 5
54-9A40

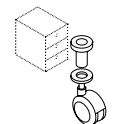

Elementi di collegamento_Connecting
elements_Verbindungselemente_Éléments
de liaison_Elements de union

64-9R31

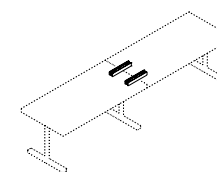

Coppia di collegamenti, piani a 90°_Pair of
connecting brackets, for 90° tops_
Halierungen für Platte 90° (Paar)_Paire de
supports pour plateaux à 90°_Par de
elementos de unión tapas a 90°

64-9R96

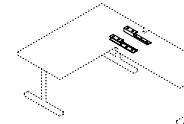

Coppia supporti per piani_Pair of connecting
brackets for tops_Stützwinkel für Platten
(Paar)_Paire de supports pour plateaux_Par
de soportes para tapas

64-9R30

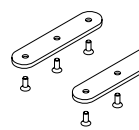

Tavolo rettangolare _Rectangular table_
Rechteckiger Tisch _Table rectangulaire_
Mesa rectangular

BN _Bianco niveo_Snow white_
 Blanc neige_Schneeweiß_Blanco niebla



BN _Bianco niveo_Snow white_
 Blanc neige_Schneeweiß_Blanco niebla



GN _Grigio nebbia_Misty grey_
 Nebelgrau_Gris brouillard_Gris niebla



GN _Grigio nebbia_Misty grey_
 Nebelgrau_Gris brouillard_Gris niebla



RL _Rovere Galles_Galles oak_Waliser
 Eiche_Chêne Galles_Roble Galles



Tavolo di servizio _Side table_ **Beistelltisch**
Table de service _Mesa de servicio

BN _Bianco niveo_Snow white_



Blanc neige_Schneeweiß_Blanco niebla



BN _Bianco niveo_Snow white_
 Blanc neige_Schneeweiß_Blanco niebla



GN _Grigio nebbia_Misty grey_
 Nebelgrau_Gris brouillard_Gris niebla



GN _Grigio nebbia_Misty grey_
 Nebelgrau_Gris brouillard_Gris niebla



YL _Melaminico giallo_Yellow melamine
 Gelb Melamin_Mélaminé jaune_
 Melaminico amarillo



AT _Melaminico amaranto_Amaranth
 melamine_Amarantrot Melamin_Mélaminé
 amarante_Melaminico carmesi



VP _Melaminico verde_Green melamine
 Grün Melamin_Mélaminé vert_Melaminico
 verde



VP _Melaminico verde_Green melamine
 Grün Melamin_Mélaminé vert_Melaminico
 verde



Cassettiera, 1cassetto_1classif. Drawer box,
1 drawer_1 filing drawer_Zwischentisch
Caisson, 1 tiroir_1 classeur_Cajonera, 1
cajón,1 carpetero

BN _Bianco niveo_Snow white_
 Blanc neige_Schneeweiß_Blanco niebla



GN _Grigio nebbia_Misty grey_
 Nebelgrau_Gris brouillard_Gris niebla



RL _Rovere Galles_Galles oak_Waliser
 Eiche_Chêne Galles_Roble Galles



YL _Melaminico giallo_Yellow melamine
 Gelb Melamin_Mélaminé jaune_
 Melaminico amarillo



AT _Melaminico amaranto_Amaranth
 melamine_Amarantrot Melamin_Mélaminé
 amarante_Melaminico carmesi



VP _Melaminico verde_Green melamine
 Grün Melamin_Mélaminé vert_Melaminico
 verde



Pannello schermo nobilitato_Melamine
 screen panel_Melamin-Abschirmpaneel_
 Panneau écran mélaminé_Panel separador
 melaminico



Pannello schermo nobilitato_Melamine
 screen panel_Melamin-Abschirmpaneel_
 Panneau écran mélaminé_Panel separador
 melaminico



Pannello schermo vetro sabbiato_Matt-finish
 screen panel_Abschirmpaneel aus Mattglas_
 Panneau écran satiné_Panel separador
 vidrio arenado



Pannello schermo vetro sabbiato_Matt-finish
 screen panel_Abschirmpaneel aus Mattglas_
 Panneau écran satiné_Panel separador
 vidrio arenado



Finiture
Finishes
Farben
Finitions
Acabados

Disponibilità di colori.
 Nell'ambito di ogni collezione non tutti
 gli articoli sono disponibili nei vari colori
 e finiture. Per un esatto controllo della
 disponibilità è consigliato l'uso del
 catalogo tecnico.

Colour availability.
 Not all the articles in each collection are
 available in the full range of colours.
 Please consult the technical catalogue for
 the exact colours available.

Verfügbare Farben.
 Innerhalb der einzelnen Kollektionen sind
 nicht alle Artikel in allen Farben erhältlich,
 die angegeben sind. Um festzustellen,
 welche Farben jeweils verfügbar sind, bitte
 den technischen Katalog nachschlagen.

Disponibilità de couleurs.
 À l'intérieur de chaque collection, tous les
 articles ne sont pas disponibles dans les
 différentes couleurs énumérées. Pour un
 contrôle exact de la disponibilité, consulter
 le catalogue technique.

Disponibilidad de colores.
 En cada colección, no todos los artículos
 están disponibles en los distintos colores
 y acabados. Para controlar exactamente
 la disponibilidad se aconseja consultar
 el catálogo técnico.

Fantoni around the world

Abruzzo, Molise, Umbria

Pescara Tel. 328/4113701

Calabria

Cosenza Tel. 0984/839183

Campania

Napoli Tel. 081/682672

Emilia Romagna

Bologna Tel. 051/226255

Friuli Venezia Giulia

Udine Tel. 0432/237346

Lazio

Frosinone, Latina Tel. 0775/872418

Roma Tel. 06/36001905

Liguria

Imperia, Savona Tel. 019/862112

Genova, La Spezia Tel. 010/530921

Lombardia

Tel. 348/2685359

Cremona, Mantova Tel. 0376/45077

Marche

Ancona Tel. 071/7108816

Piemonte

Cuneo Tel. 019/862112

Torino Tel. 011/6813778

Puglia e Basilicata

Bari Tel. 080/5541072

Sardegna

Cagliari Tel. 348/3315783

Sicilia

Agrigento, Caltanissetta, Palermo,

Trapani Tel. 091/408522

Catania, Enna, Messina, Ragusa,

Siracusa Tel. 095/449665

Toscana

Sesto Fiorentino Tel. 055/340077

Trentino Alto Adige

Tel. 0461/955777

Bolzano Tel. 335/6042826

Val d'Aosta

Torino Tel. 011/6813778

Veneto

Belluno, Treviso Tel. 0423/737544

Padova, Vicenza Tel. 049/8756766

Rovigo, Venezia Tel. 041/5040891

Albania

Tirana Tel. +335/682066851

Australia

Melbourne Tel. +61/3/9654/8522

Sydney Tel. +61/2/9690/0077

Austria

Tel. +39/335/6042826

Armenia, Azerbaijan, Georgia

Tel. +39/335/1800240

Bahrain

Tel. +39/335/6120608

Belgium

Gent Tel. +32/9/2581470

Bosnia

Tel. +39/348/2332988

Sarajevo Tel. +387/33/214570

Bulgaria

Sofia Tel. +359/2/8557818

Canada

Montreal Tel. +1/514/8422463

China

Tel. +86/769/88873266

Hong Kong, Macau

Tel. +852/23893989

Corea

Seoul Tel. +82/2/7633361

Croatia

Tel. +39/348/2332988

Zagreb Tel. +385/1/4922759

Cyprus

Nicosia Tel. +357/22/485345

Czech Republic

Tel. +39/348/2332988

Prague Tel. +420/2/221729222

Denmark

Odense Tel. +45/66117411

Dominican Republic

Santo Domingo Tel. +1/809/4720022

Estonia, Latvia, Lithuania

Tel. +39/335/1800240

France

Nord - Strasbourg Tel.

+33/3/88234623

Sud - Albi Tel. +33/5/63773030

Germany

Berlin Tel. +49/30/33771211

Hamburg Tel. +49/40/894989

Munich Tel. +49/89/61019779

Stuttgart Tel. +49/7125/407060

Greece

Athens Tel. +30/210/6154800

Thessaloniki Tel. +30/2310/463533-4

Hungary

Tel. +39/335/1329026

Kazakhstan

Tel. +39/335/1800240

Kuwait

Tel. +39/335/6120608

India

Tel. +39/349/7803661

Bangalore Tel. +91/80/65365111

Kolkata Tel. +91/033/22835711

New Delhi Tel. +91/981/1436253

Indonesia

Jakarta Tel. +62/21/53652593

Israel

Tel Aviv Tel. +972/3/6474465

Japan

Tel. +43/664/5419707

Tel. +81/335/127534

Lebanon

Beirut Tel. +961/1/360233

Luxembourg

Tel. +32/9/2581470

Malta

Tel. +356/21/446000

Marocco

Tel. +212/022/353755

Mexico

Mexico D.F. Tel. +52/5552828957

Moldavia, Ukraine

Tel. +39/335/1800240

Netherlands

Tel. +32/9/2581470

Norway

Oslo Tel. +47/23133070

Oman

Tel. +39/335/6120608

Poland

Tel. +39/348/2332988

Katowice Tel. +48/32/2039384

Warsaw Tel. +48/22/3225000

Puerto Rico

San Juan Tel. +1/787/7288382

Portugal

Tel. +39/349/7803661

Qatar

Tel. +39/335/6120608

Romania

Tel. +39/348/2332988

Bucaresti Tel. +40/21/2505411

Russia

Tel. +7/495/9255055

Saudi Arabia

Tel. +39/335/6120608

Slovakia

Tel. +39/348/2332988

Bratislava Tel. +421/2/64461991

Slovenia

Tel. +39/348/2332988

Ljubljana Tel. +386/1/4211464

Spain

Las Palmas Tel. +34/9/28368211

Madrid Tel. +34/91/4428411

San Sebastian Tel. +34/9/43444450

Tenerife Tel. +34/9/22249624

Valencia Tel. +34/96/3380980

Switzerland

Ticino Canton Tel. +39/348/2685359

Zurich Tel. +41/44/2724442

Taiwan

Taipei Tel. +886/2/2516/5226

Turkey

Istanbul Tel. +90/212/2165320

United Kingdom

Godalming, Surrey

Tel. +44/1483/527996

United Arab Emirates

Tel. +39/335/6120608

Dubai Tel. +971/6/5574143

Usa

Chicago Tel. +1/312/6649582

Denver Tel. +1/831/6251458

Los Angeles Tel. +1/310/6598400

Miami Tel. +1/305/4487367

New York Tel. +1/646/4788463

San Francisco Tel. +1/831/6251458

Seattle Tel. +1/206/6222433

Venezuela

Caracas Tel. +58/2/2677712

Yugoslavia

Beograd Tel. +38/111/3037303

Fantoni Spa

I-33010 Osoppo / Udine

Telefono +39 0432 9761

Telefax +39 0432 976266

info@fantoni.it

www.fantoni.it

Photo: Alessandro Paderni / Eye

Copy: Daniele Varelli

Artwork: Adriano Ferrara

Translation: Studio Intra

Print / Colour separation:

Grafiche Manzanesi